

KING^{US}
Machinery and
Engineering
Corp.

Green

Smart Control

Design



SINGLE SLIDE

Vertical Single Slide Injection Molding Machine

Vertical Single Slide Injection Molding Machine

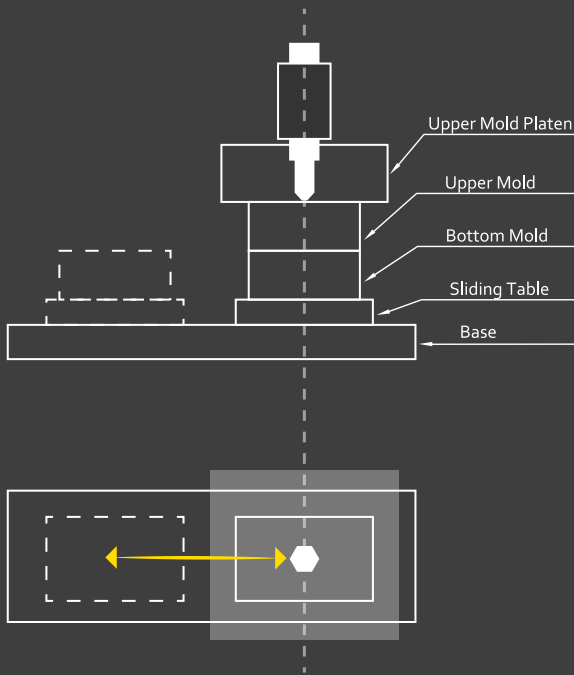

- Vertical direct hydraulic clamping system is designed for accurate, safe operation, especially suitable for insert molding.
- Precision vertical clamping system (parallelism/ flatness : 0.02/ 100mm), heavy-duty tie-bars, and low-pressure mold clamping work together to greatly extend machine & mold life.
- With single slide design, product from the bottom mold to make the operation safe and efficient and enhance yield.
- Nitridened slide table and base, Hardness HRC50~52°, wear resisting and anti-corrosion.



Vertical Hydraulic Clamping System



Operator-friendly



Safety Design For Operator



Energy Saving

Model		
INJECTION UNIT		
Screw Diameter	mm	
Injection Capacity	cm ³	
Injection Pressure	kgf/cm ²	
Injection Weight	oz	
	gram	
Injection Rate	cc/s.	
Injection Rate	mm/s.	
Screw Speed	r.p.m.	
Screw Stroke	mm	
Nozzle Stroke	mm	
Nozzle Contact Force	ton	
CLAMPING UNIT		
Clamping Force	ton	
Minimum Mold Height	mm	
Opening Stroke	mm	
Maximum Daylight	mm	
Overall Size Of Platens	mm	
Space Between Columns	mm	
Size Of Sliding Table	mm	
Single Slide Table Stroke	mm	
Ejector Force(Outside)	ton	
Ejector Stroke(Outside)	mm	
ELECTRICAL EQUIPMENT & GENERAL		
Power Source	v/hz	
Drive Motor	kW	
Heater	kW	
Temperature Control Zone	zone	
Hydraulic System Pressure	kgf/cm ²	
Machine Dimension	m	
Machine Weight	ton	

KING'S Solution Corp.

Taiwan : No.457, Nanshang Rd., Guishan Dist, Taoyuan City 33392, Taiwan | sales@kingsmachinery.com.tw | Tel : +886-3-3218768 | Fax : +886-3-3218769

China : Bao Xin Industrial Park, Wu Village ,Chen Jiang Town, Hui Zhou City Guangdong | Tel : +86-752-3269005/07 | Fax : +86-752-3269360/350

www.injection.com.tw/ | www.facebook.com/Kingsmachinery/ | https://www.youtube.com/user/kingsmachinery/